

# 9177 Series

## Wire to Board IDC Connector

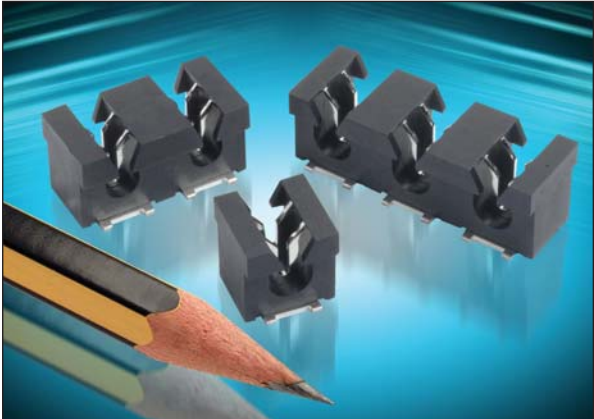

The 9177 Series from AVX offers customers the ability of connecting individual wires to a single row of contact using IDC technology.

Available as a single contact version or 2 and 3 way offers the user flexibility of placement on the PCB for single or multiple wires.

Application tooling for the 9177 comes in the form of flat rock plates for each of the sizes. The wires are inserted into the slots by the application tools cutting through the insulation and exposing the inner cores, which then form a homogenous joint with the contact.

The molding is shaped to form a restraint to the wire insulation therefore adding to the strength of the joint. Supplied in tape and reel for easy pick and place. Suitable wire options are stranded wire between 14 and 20 AWG.

For wire diameters you do not see listed please consult the factory for recommendations.

### APPLICATIONS

- Termination of any individual wires within the specified wire range to a PCB
- High power termination to 15 amps
- Voltage critical areas up to 650V

### FEATURES AND BENEFITS

- Eliminates the need for hand soldering
- Connectors are end to end stackable for larger pin counts
- Uses stranded wire with no preparation
- Integrated cable restraint within the molding
- Offers a fit and forget termination by using IDC
- Tooling allows mass termination of each connector size

### HOW TO ORDER

**00**   **9177**   **00X**

Prefix   Series   Number of Ways

001 = 1  
002 = 2  
003 = 3

**0XX**

Wire Gauge Size

Code	Accepted Wire Gauge	Wire Insulation
001	14 AWG	ø4.25 max
012	16 AWG	ø3.50 max
022	18 AWG	ø3.50 max
033	20 AWG	ø2.75 max

**X**

Insulator Color

Code	Color	Availability
0	Black	Standard
1	White	Optional

**06**

Plating Option

06 = Pure Tin All Over



# 9177 Series



## Wire to Board IDC Connector

### 1 WAY IDC CONNECTOR

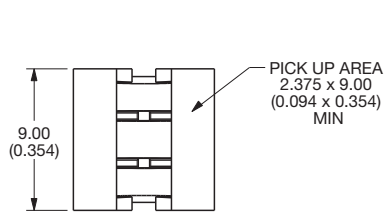

### 2 WAY IDC CONNECTOR

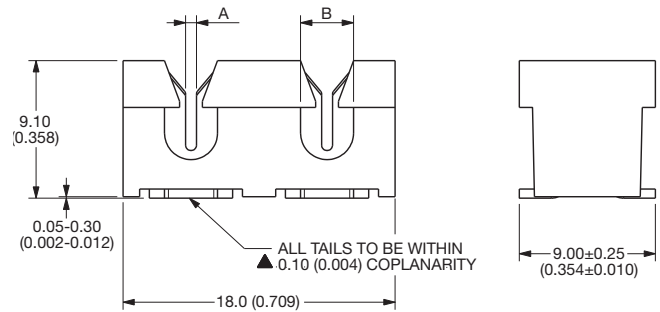
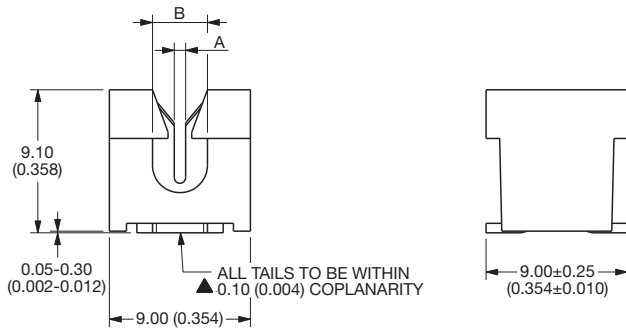
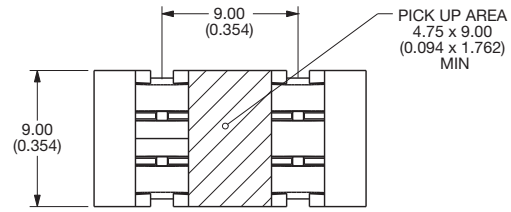

### SMT PCB LAYOUT

PURE TIN PADS

### SMT PCB LAYOUT

PURE TIN PADS

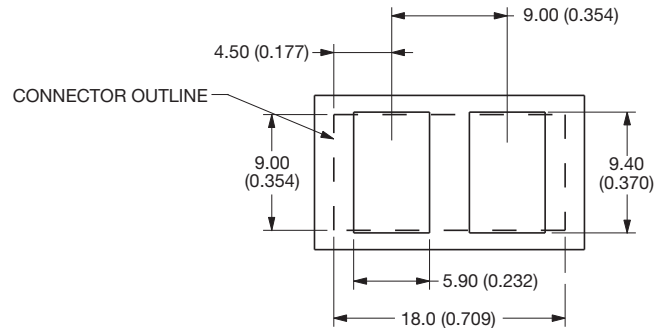
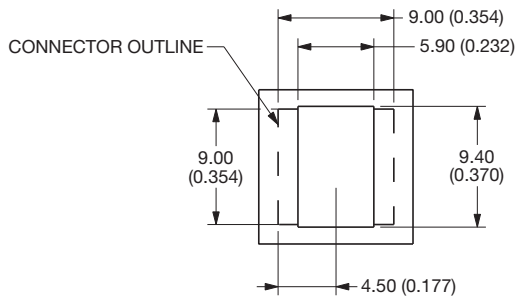

### 3 WAY IDC CONNECTOR

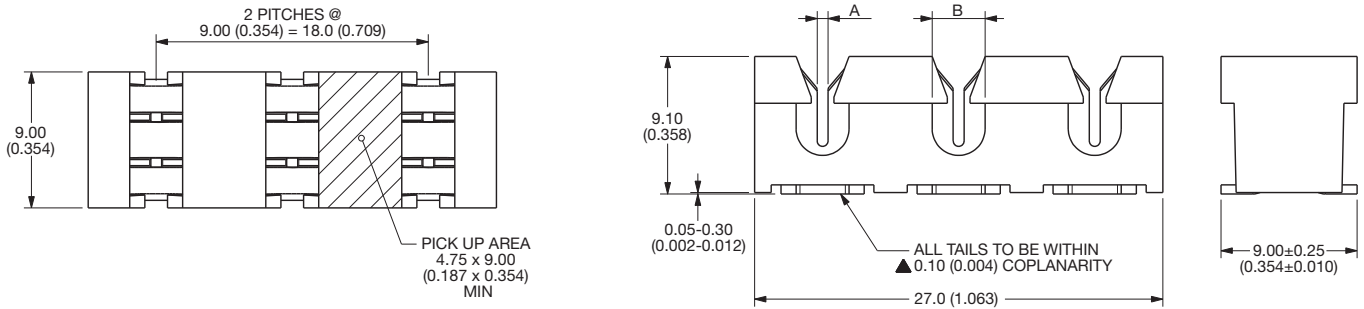

### SMT PCB LAYOUT

PURE TIN PADS

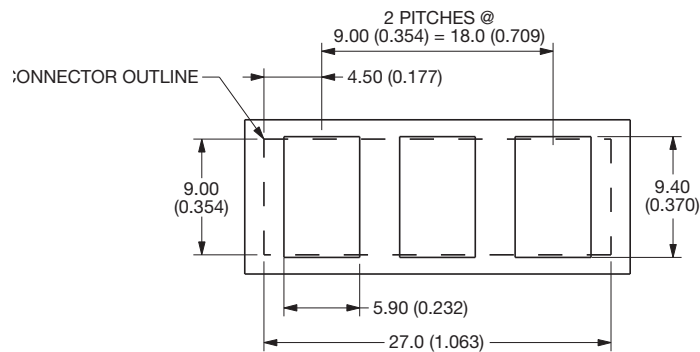

### HAND INSERTION TOOLING

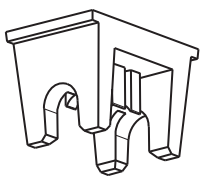

1 WAY

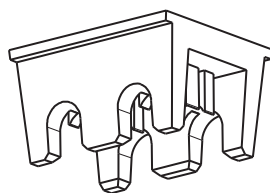

2 WAY

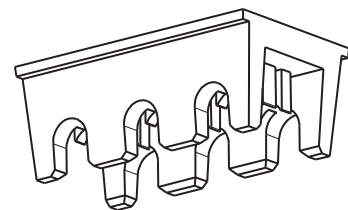

3 WAY

### HIGH PRODUCTION

METAL

No. of Ways	Max Insulation Dia.	Tool Part Number
1	∅ 4.25	06 9177 7017 01 001
	∅ 3.50	06 9177 7017 02 001
	∅ 2.75	06 9177 7017 03 001
2	∅ 4.25	06 9177 7017 01 002
	∅ 3.50	06 9177 7017 02 002
	∅ 2.75	06 9177 7017 03 002
3	∅ 4.25	06 9177 7017 01 003
	∅ 3.50	06 9177 7017 02 003
	∅ 2.75	06 9177 7017 03 003

### MED PRODUCTION

PLASTIC

No. of Ways	Max Insulation Dia.	Tool Part Number
1	∅ 4.25	06 9177 7016 01 001
	∅ 3.50	06 9177 7016 02 001
	∅ 2.75	06 9177 7016 03 001
2	∅ 4.25	06 9177 7016 01 002
	∅ 3.50	06 9177 7016 02 002
	∅ 2.75	06 9177 7016 03 002
3	∅ 4.25	06 9177 7016 01 003
	∅ 3.50	06 9177 7016 02 003
	∅ 2.75	06 9177 7016 03 003